

INFORMATION GUIDE
FOR
INSTALLATION/OPERATION
OF ECLIPSE MARK IV
COMBINATION GAS/OIL BURNERS
SERIES "MF"

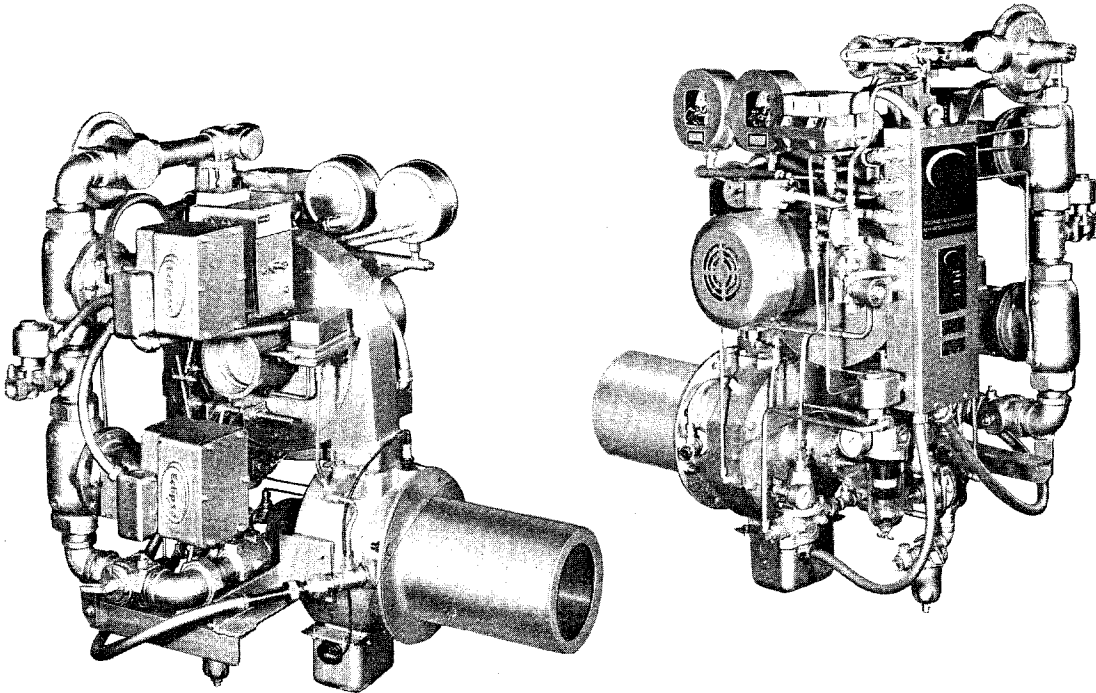

100 & 200 MF-CGO-IRI(FIA)

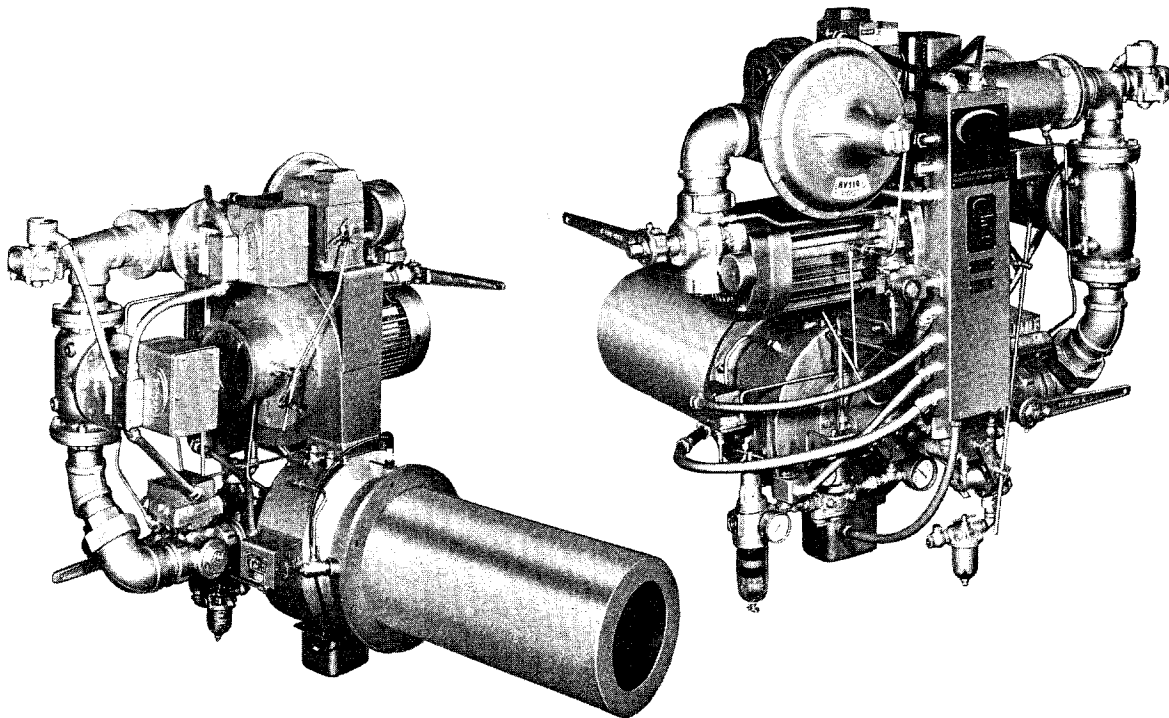

ECLIPSE COMBUSTION

THIS INFORMATION GUIDE IS INTENDED TO AID THE CUSTOMER IN THE INITIAL INSTALLATION, WIRING, PIPING AND ADJUSTMENT OF COMPLETE, MF-CGO-IRI (FIA) BURNERS

1.0 MOUNTING THE BURNER (See Figures 1 & 2)

- 1.1 Figure 1 illustrates burner mounting when there is access to the inside of the appliance wall. This method is preferred since the tube can be removed for replacement or to allow servicing of the nozzle without disturbing the burner or its linkage and piping. Figure 2 illustrates burner mounting when there is no access to the inside of the appliance wall. The studs are pressed in or welded to the wall. The burner and the tube mount from the outside. The nozzle can be removed through the rear of the burner in these installations.
- 1.2 If the burner weight is to be supported entirely by the appliance wall, the wall must be at least 1/4" thick plate. If it is not, support must be provided for the burner.
- 1.3 Bolts or studs can be utilized to mount the burner and firing tube to the appliance wall. Care should be taken to match the mounting bolt pattern to the burner mounting flange bolt circle. All Mark IV Burners and firing tubes have (8) 9/16" dia. holes for mounting. Bolt circle diameters are as follows : 100 and 200 MF, 10-1/2"; 300 and 500 MF, 14-5/8". Bolts or studs used for mounting should be 1/2" N. C.
- 1.4 An adequately sized opening must be provided in the appliance wall to provide clearance for the burner firing tube. If the appliance wall is insulated, 4" additional clearance should be provided all around the firing tube so air can circulate around the tube and protect the firing tube from overheating in the area of the insulation.
- 1.5 If the burner has been supplied with a combustion block, refer to P-5 Installation Instructions covering combustion blocks and block holders.

FIGURE 1
MOUNTING
WITH ACCESS TO INSIDE OF APPLIANCE

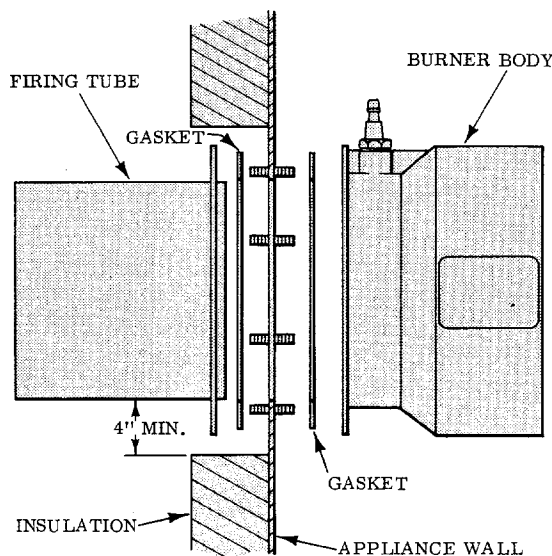
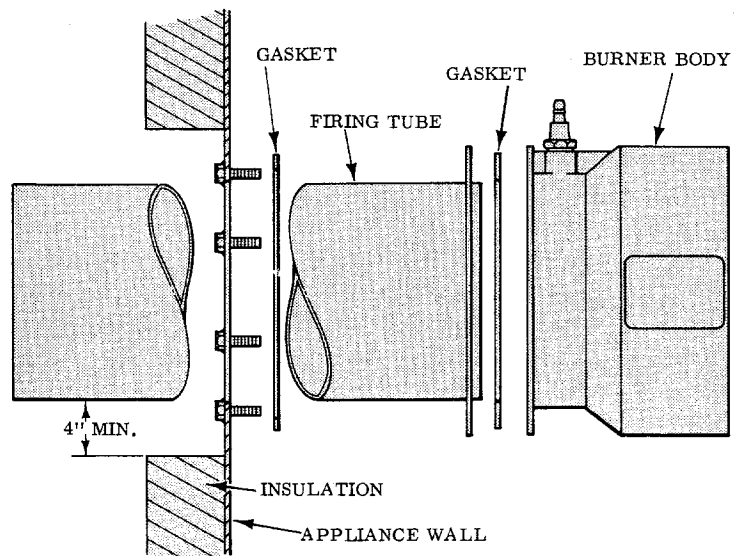

FIGURE 2
MOUNTING
WITH NO ACCESS TO INSIDE OF APPLIANCE



2.0 ELECTRICAL CONNECTIONS

- 2.1 All electrical equipment furnished with the "Complete" Mark IV Burner is prewired to a terminal strip. See Figure 3.
- 2.2 A COMBUSTION CONTROL PANEL IS REQUIRED FOR ALL MARK IV BURNERS. Figure 4 illustrates the suggested control panel wiring diagram and operating sequence. Interface wiring between the control panel and the burner terminal strip must be done correctly and electrical sources supplying power to the burner must be of proper voltage and frequency. The three phase motor supplied with the Mark IV burner to drive the combustion air fan has been wired for the voltage requested on the customer's order. If motor voltage is questioned, check motor nameplate and physical wiring in the motor terminal box. The Eclipse Mark IV Burner is not supplied standard with flame monitoring equipment. Eclipse offers three different scanner mounting parts groups : a PCI scanner; a Honeywell scanner; or a Fireye scanner. If ordered, each is installed on the burner with necessary fittings and conduit and wired to the terminal strip. It is the customer's responsibility to provide a compatible relay in the control panel. If the Mark IV burner has been ordered without one of the three scanner mounting parts groups, it is also the customer's responsibility to provide a scanner for mounting on the burner and all wiring from the scanner to the relay. IMPORTANT : Do not attempt to operate this burner without adequate flame monitoring equipment. The owner/user and/or his insurance underwriter must assume responsibility for the acceptance, use, and proper maintenance of the limit controls and other safety devices included with this burner as well as flame supervision provided in the control panel and the interfacing of all electrical equipment and sequencing of burner operation between the control panel and the burner.

FIGURE 3
TERMINAL STRIP WIRING DIAGRAM FOR MF-CGO-IRI(FIA) BURNER

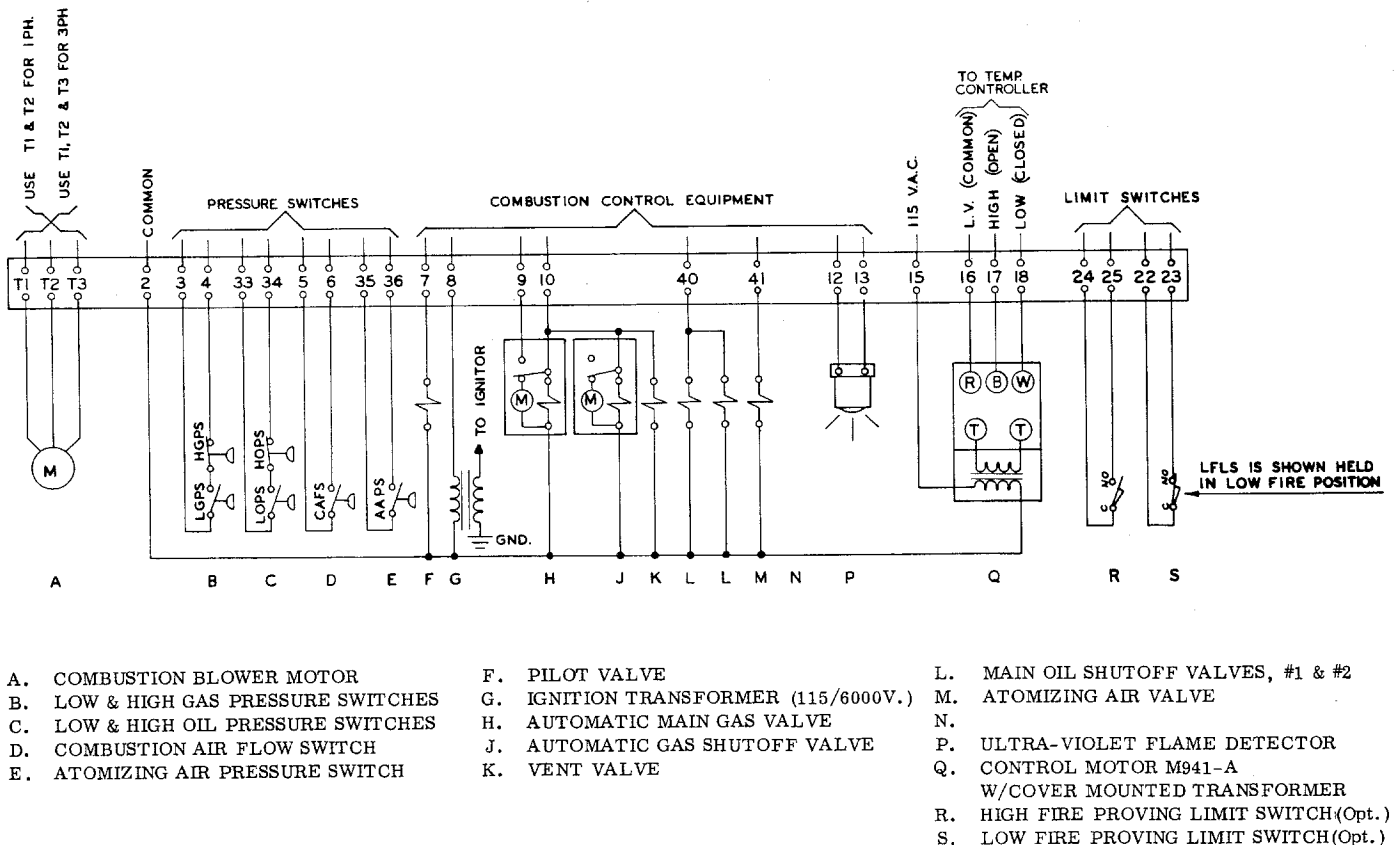

FIGURE 4
SEQUENCE OF OPERATION FOR SUGGESTED CONTROL PANEL

GAS OPERATION SEQUENCE

Power on, fuel selector in "GAS" position

1. The "start" push button is depressed, powering the "MS" motor starter coil through the "MS-OLS" N.C. contacts.
2. The "MS" N.O. auxiliary contacts close; to hold in the start circuit and initiate the F.S. limit circuit.
3. The combustion blower motor starts to run and the "CAFS" combustion air flow switch closes, causing the "blower on" yellow light to illuminate.
4. If the customer's "ELC" external limiting circuit is closed and all necessary fuel pressure switches are closed, power will pass through the "gas-oil" selector switch and "TR2" and "CR2" N.C. contacts to energize "CR1" relay.
5. The "CR1" N.C. and N.O. contacts reverse to drive "TCA" control motor to the high fire (open register) position.
6. The "HFLS" high fire proving limit switch closes to power the "PPT" pre-purge timer and illuminate the "purging" amber light through "PPT" N.C. contact.
7. When the 0-5 min. adjustable, pre-purge timer times out, it switches to energize "CR2" relay and turn off the "purging" amber light.
8. The "CR2" N.C. contact opens to de-energize "CR1" relay and "CR2" N.O. contact closes for "PPT" timer holding circuit.
9. The "CR1" N.C. and N.O. contacts return to normal position and the "TCA" control motor drives back to low.
10. The "LFLS" low fire proving limit switch closes to power term. 1 on the protectofier and starts the ignition cycle.
11. Protectofier term. 3 powers the ignition transformer through "TR1" N.C. contact; the pilot valve through "TR2" N.C. contact; and "TR1" timed relay (10 sec.).
12. Protectofier term. 5 powers the "flame on" blue light.
13. After 10 sec. delay; "TR1" N.C. contact opens, to de-energize the ignition transformer; "TR1" N.O. contact closes to hold in circuit around the "PPT" timer and "LFLS" low fire proving limit switch; and "TR1" N.O. contact closes to energize the main gas valve, the gas shutoff valve and the vent valve.
14. When the main gas valve is fully opened, it switches to illuminate the "gas burner on" green light, and energize "TR2" timed relay (10 sec.).
15. After 10 sec. delay: "TR2" N.C. contact opens to reset the purge timer; "TR2" N.C. contact opens to de-energize the pilot gas valve; and "TR2" N.C. and N.O. contacts reverse to release the "TCA" control motor from low fire start.
16. Burner is now on (flame proven) and operating from temperature controller.

OIL OPERATION SEQUENCE

Power on, fuel selector in "OIL" position

1. The "start" push button is depressed, powering the "MS" motor starter coil through the "MS-OLS" N.C. contacts.
2. The "MS" N.O. Auxiliary contacts close; to hold in the start circuit and initiate the F.S. limit circuit.
3. The combustion blower motor starts to run and the "CAFS" comb. air flow switch closes, causing the "blower on" yellow light to illuminate.
4. If the customer's "ELC" external limiting circuit is closed and all necessary fuel pressure switches are closed, power will pass through to the "gas-oil" selector switch and "TR2" and "CR2" N.C. contacts to energize "CR1" relay.
5. The "CR1" N.C. and N.O. contacts reverse to drive "TCA" control motor to the high fire (open register) position.
6. The "HFLS" high fire proving limit switch closes to power the "PPT" pre-purge timer and illuminate the "purging" amber light through "PPT" N.C. contact.
7. When the 0-5 min. adjustable, pre-pruge timer times out, it switches to energize "CR2" relay and turn off the "purging" amber light.
8. The "CR2" N.C. contact opens to de-energize "CR1" relay and "CR2" N.O. contact closes for "PPT" timer holding circuit.
9. The "CR1" N.C. and N.O. contacts return to normal position and the "TCA" control motor drives back to low.
10. The "LFLS" low fire proving limit switch closes to power term. 1 on the protectofier and starts the ignition cycle.
11. Protectofier term. 3 powers the ignition transformer through "TR1" N.C. contact; the pilot valve through "TR2" N.C. contact; and "TR1" timed relay (10 Sec.).
12. Protectofier term. 5 powers the "flame on" blue light.
13. After 10 sec. delay; "TR1" N.C. contact opens to de-energize the ignition transformer; "TR1" N.O. contact closes to hold in circuit around the "PPT" timer and "LFLS" low fire proving switch; and "TR1" N.O. contact closes to energize the atomizing air valve.
14. The "AAPS" atomizing air pressure switch should close, shortly after the atomizing air valve is powered; to power the main oil valves to illuminate the "oil burner on" green light, and energize "TR2" timed relay (10 Sec.).
15. After 10 sec. delay; "TR2" N.C. contact opens to reset the purge timer; "TR2" N.C. contact opens to de-energize the pilot gas valve; and "TR2" N.C. and N.O. contacts reverse to release the "TCA" control motor from low fire start.
16. Burner is now on (flame proven) and operating from temperature controller.

BILL C

MF Burner Equipment

- LGPS - Low Gas Pressure Switch
- HGPS - High Pressure Switch
- LOPS - Low Oil Pressure Switch
- HOPS - High Oil Pressure Switch
- CAFS - Combustion Air Flow Switch
- AAPS - Atomizing Air Pressure Switch
- LFLS - Low Fire Proving Limit Switch, (Optional)
- HFLS - High Fire Proving Limit Switch, (Optional)
- PGV - Pilot Gas Valve
- PIT - Ignition Transformer (115/6000 V)
- VGW - Vent Valve (N.O.)
- SGV - Automatic Gas Shutoff Valve
- MGV - Automatic Main Gas Valve
- MOV1 - Main Oil Shutoff Valve #1
- MOV2 - Main Oil Shutoff Valve #2
- AAV - Atomizing Air Valve
- UVS - Ultra-Violet Flame Detector
- TCA - Control Motor (Electric) (Honeywell shown)

1. Three phase voltage supply must be noted breaker, motor starter and control circuit.
2. Motor Horse Power:

BURNER	STANDAR
100 MF	3
200 MF	1
300 MF	2
500 MF	3

3. Control Circuit Transformer (230/460V./115V. or 575V./115V.)
 230V. Primary - H1 is jumpered to H3
 460V. Primary - H3 is jumpered to H2
 575V. Primary - 575V. transformer is

FIGURE 4
WIRING DIAGRAM FOR SUGGESTED CONTROL PANEL

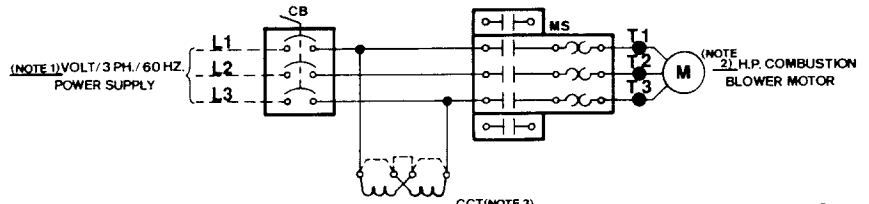

MATERIAL

Panel Equipment

- CB - Circuit Break or Disconnect Switch (See Note 1)
- MS - Motor Starter (See Note 1)
- CCT - Control Circuit Transformer (See Notes 1 & 3)
- FI - Fuse
- PPT - Pre-Purge Timer (0-5 Min. Adj.)
- 7256BH - P.C.I. Protectofier Combustion Safeguard
- AH - Alarm Horn (Flame Failure Lockout)
- CR1 - Relay, Drive Control Motor to high fire position
- CR2 - Relay, interrupts power to CR1 and provides holding circuit for purge timer.
- TR1 - Timed Relay (10 sec.) interrupted ignition, F.S. holding circuit and delay on energizing main fuel valves.
- TR2 - Timed Relay (10 sec.) interrupted pilot, low fire start and purge timer reset.

External Equipment

- ELC - External Limiting Circuit (Example-- High Temp. Limit Switch)
- TC - Temperature Controller (Partlow Shown)

NOTES

formal order, to obtain the proper sizing of circuit transformer.

BLOWER	OPTIONAL BLOWER
H. P.	3/4 H. P.
H. P.	1-1/2 H. P.
H. P.	3 H. P.
H. P.	5 H. P.

H2 is jumpered to H4.

used (no jumpers).

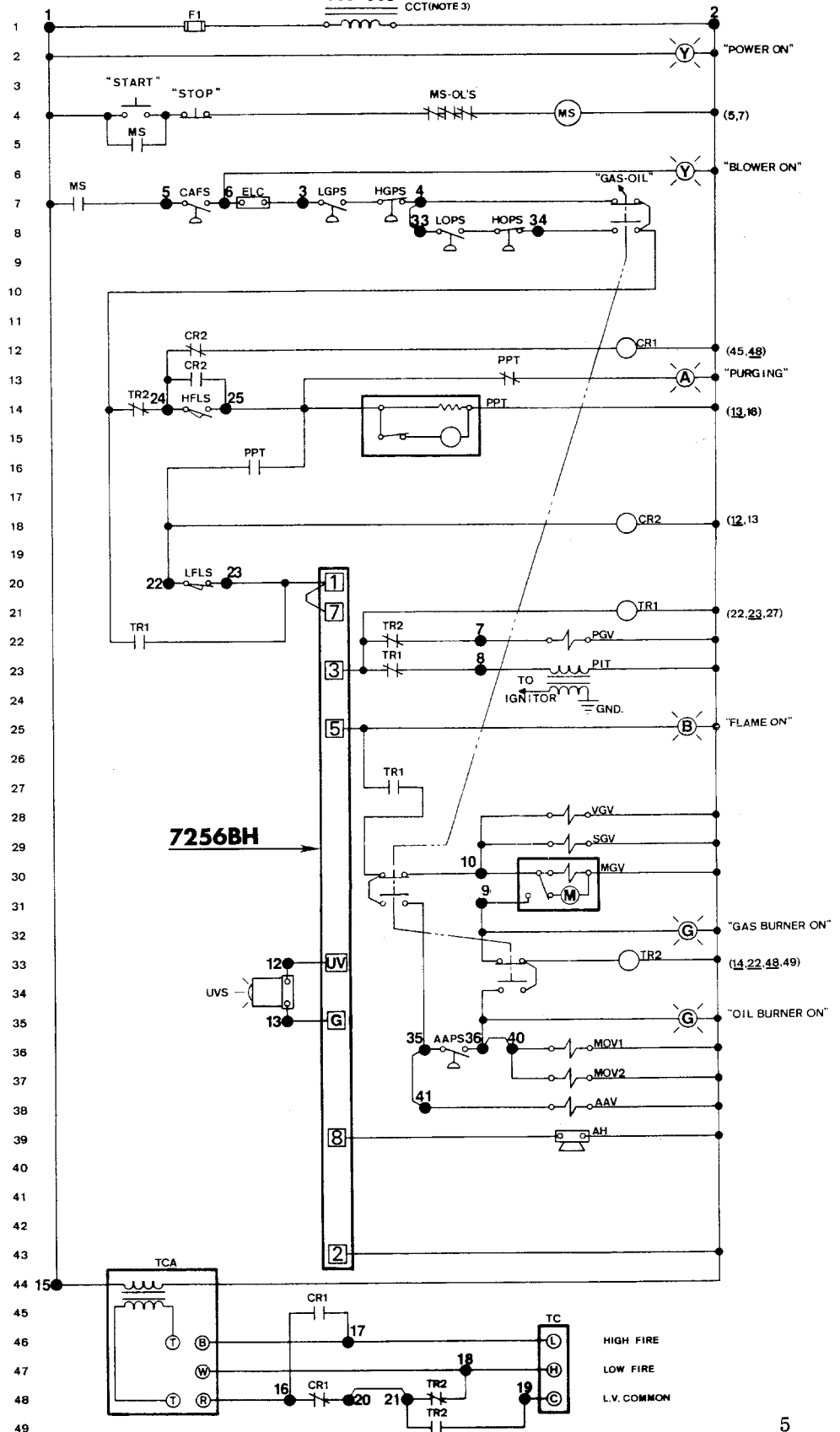

3.0 GAS, OIL AND ATOMIZING AIR PIPING (See Figures 5 & 6)

- 3.1 All field piping, particularly the fuel oil and atomizing air supply pipes, should be inspected during field assembly to insure they are free from foreign material and pipe scale. Use of clean pipe will help ensure trouble free startup and operation.
- 3.2 Never use Teflon tape for field piping connections. Since commercial piping usually does require some type of sealant on the threads to ensure leak free connections, Eclipse suggests the use of Loctite Teflon Pipe Sealant #92-31. Any pipe sealant used should be applied with care and excess sealant should be removed before joints are made up. Fittings should be torqued to 60 in. lb. \pm 20 in. lb.
- 3.3 Eclipse recommends that suitable pipe union disconnects be used in the pipe trains as near to the burner as is convenient. Burner pipe sizes supplied on the burner are adequate for short piping runs. If longer piping runs are to be utilized, piping loss must be taken into consideration and pipe sized accordingly.
- 3.4 Refer to Figure 6 for pressures required at the burner valve train inlets.
- 3.5 It is the customer's responsibility to install proper gas pressure regulators in the gas line so the gas supply will be as indicated in Figure 6 and steady.
- 3.6 It is the customer's responsibility to supply #2 or lighter fuel oil to the burner at the steady pressure indicated in Figure 6. The fuel supply must be clean and it is the customer's responsibility to supply filters and strainers capable of removing particles larger than 40 microns in the oil pipe line. The oil filter on the burner should be considered only as a final filter.
- 3.7 It is the customer's responsibility to supply compressed air to the atomizing air valve train at the pressure indicated in the chart. The atomizing air must be clean (40 micron maximum partical size) and dry (Dew Point 30^o F. below ambient). The customer is to supply adequate dryers and filters in the atomizing air supply piping. The filter and moisture separator supplied on the burner assembly should be considered only as a final filter and separator.
- 3.8 All piping should be checked for leakage before attempting initial lightoff.
- 3.9 See Figure 6A for pressures at locations A, B, C and D on Figure 5.

**FIGURE 5
COMPONENT IDENTIFICATION**

This schematic shows the order in which the components appear in the valve trains and the approximate location where the valve trains connect to the burner. The pressure checking cocks are also shown in their approximate locations. This schematic is NOT an exact representation of the burner's appearance and is intended only to aid in identification of the various components.

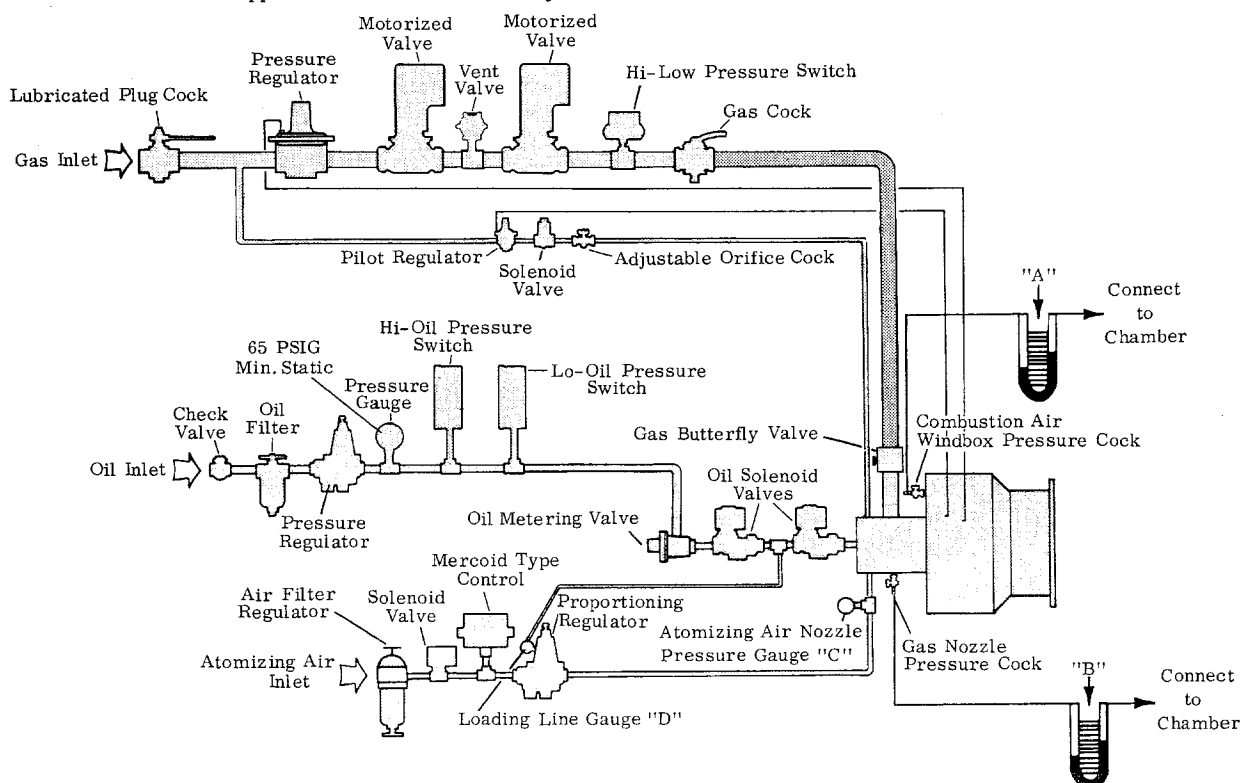

FIGURE 6

Inlet Pressure Requirements*

Burner Cat. No.	Nat. Gas .65 SP. GR.	Propane 1.52 SP. GR.	#2 Fuel Oil	Atomizing Air Req'd. Flow & Pressure
100 MF	14"-28" w.c.	6"-12" w.c.	75-100 psig	3.25 scfm @ 65-100 psig
200 MF	14"-28" w.c.	6"-12" w.c.	75-100 psig	3.25 scfm @ 65-100 psig
300 MF	14"-28" w.c.	6"-12" w.c.	75-100 psig	13.0 scfm @ 65-100 psig
500 MF	14"-28" w.c.	6"-12" w.c.	75-100 psig	14.5 scfm @ 65-100 psig

*Figures are for complete burners only and are taken at the valve train inlets.

FIGURE 6 A

Burner Cat. No.	A		B		C		D
	Combustion Air Pressure "W.C.		Nat. Gas. Press. "W.C. (.65 SP. GR.)	Propane Press. "W.C. (1.52 SP. GR.)	Atomizing Air Pressure PSIG		Oil Loading Press. PSIG
	Low Fire	High Fire	High Fire	High Fire	Low Fire	High Fire	High Fire
100 MF	.2	7.3	6.4	2.6	20	45	50
200 MF	.15	5.5	12	4.8	20	45	50
300 MF	.2	6.0	5.8	2.3	10	45	55
500 MF	.2	6.0	4.6	1.8	20	45	50

NOTE: All above pressure settings are approximate. For actual settings, refer to the tags supplied with the burner.

4.0 INITIAL LIGHTOFF

- 4.1 The burner has been test fired and adjusted at the factory. If duct suction/pressure varies no more than .5" w.c. from neutral, no further adjustments should be required to put the burner in operation.
- 4.2 On a new installation the gas pipe line usually requires some purging to remove trapped air from the gas line. On a new installation it is recommended that the oil pipe line be bled before attempting a startup. This is to remove the foreign materials normally found in new systems.
- 4.3 Before attempting initial lightoff, refer to any instructions included with the control panel and familiarize yourself with the sequence of operation that is under control of the panel.
- 4.4 When observing the burner fuel and air controls, it should be noted that the control motor (air or electric) and the connected flow control valves (air, gas and oil) move through an arc of approximately 90°. The flow control valves are preset at the factory, however the linkage can be readjusted to obtain the exact low and high fire capacities desired (see 5.0 or 6.0).

4.5 PILOT IGNITION

- 4.5.1 Read control panel instructions and set panel for desired fuel.
- 4.5.2 Open inlet lubricated plug cock and adjustable orifice pilot cock.
- 4.5.3 Begin ignition sequence on control panel. Check for spark and opening of the pilot solenoid valve.
- 4.5.4 Several trials for ignition may be required if the piping was inadequately purged.
- 4.5.5 If, after several tries, ignition cannot be established with the pilot solenoid valve open and spark present, it will be necessary to adjust the adjustable orifice pilot cock.

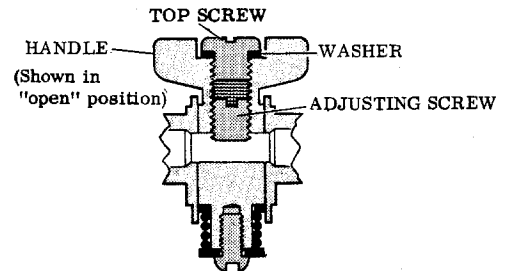

- 4.5.6 To adjust the pilot cock, remove the top screw and top screw washer. This gives access to the adjusting screw. Turn the adjusting screw "In" for less gas or "Out" for more. Replace washer and top screw.

4.6 MAIN FLAME IGNITION

- 4.6.1 Once the pilot is established, open the gas cock (gas operation ONLY). The motorized gas valves or oil solenoid valves should open.
- 4.6.2 Check the gas or oil pressure and atomizing air pressure (Oil ONLY) at low fire. If they are not the same as those on the test tags, adjustments will be necessary (see 5.0 or 6.0).
- 4.6.3 Check the gas or oil pressure and atomizing air pressure (Oil ONLY) at high fire. If they are not the same as those on the test tags, adjustments will be necessary (see 5.0 or 6.0).
- 4.6.4 After all adjustments have been made, run the burner through its complete operating range, from full off to high fire, several times.

5.0 LINKAGE ADJUSTMENT - 100 & 200 MF (See Figures 5 & 7)

- 5.1 The components involved in the linkage are as follows: Rod A and Driven Arm A transfer the motion of the control motor to the jackshaft; Driving Arm B, Rod B and Driven Arm B1 transfer motion from the jackshaft to the combustion air butterfly valve; Driving Arm C, Rod C and Driven Arm C1 transfer motion from the jackshaft to the gas butterfly valve; Driving Arm D, Rod D and Driven Arm D1 transfer motion from the jackshaft to the oil metering valve.
- 5.2 All linkage arms move in an upward direction when going from low to high fire.
- 5.3 When adjusting linkage, start with the driving and driven arms approximately parallel to each other. (Does not apply to the gas butterfly valve. See photo for approximate position).
- 5.4 Lengthening the distance between the rotating center of the driving arm and the link connecting point on the driving arm will cause the driven arm to move through a larger angle. Shortening this distance will cause the driven arm to move through a smaller angle. Making these adjustments on the driven arm will reverse the results.
- 5.5 All linkage adjustments, including those which will alter the high fire rate, must be made with the burner at low fire. Care should be taken not to alter the low fire setting, as it serves as a constant reference point. Making an adjustment at the link connecting point ONLY will alter both the high and low firing rates. To maintain one firing rate while changing the other, the link and rod connecting points must both be loosened.
- 5.6 Adjust Rod and Arm A so that the jackshaft will rotate 90° as the control motor drives from low to high fire.

5.7 COMBUSTION AIR FLOW ADJUSTMENT

- 5.7.1 Close the lubricated plug cock and the oil solenoid valves, set the control motor at low fire and start the combustion air blower.
- 5.7.2 Loosen the link and rod connecting points at Arm B1, set the butterfly valve to give a differential pressure between the burner windbox and the firing chamber of approximately .25" w.c. (low fire).
- 5.7.3 Tighten the loose connecting points.
- 5.7.4 Drive the control motor to high fire. The differential pressure should be 6" w.c. If it is not, return to low fire, loosen the link and rod connecting points at either Arm B or B1 and move the link connecting point in the appropriate direction (see 5.4) without moving Arms B and B1 or changing the low fire air flow rate.
- 5.7.5 Tighten the loose connecting points and recheck the high fire differential pressure. Once the burner is firing, it may be necessary to readjust the air flow slightly.

5.8 GAS FLOW ADJUSTMENT

- 5.8.1 Make sure the burner is in the gas operation mode. Refer back to 4.0, light the burner and set the control motor for low fire.
- 5.8.2 If the butterfly valve does not go to the full "Off" position or if it is at full "Off" and there is not sufficient leakage past the butterfly to maintain a stable low fire, loosen the link and rod connecting points at Arm C1 and move Arm C1 in the appropriate direction (see 5.4).
- 5.8.3 Tighten the loose connecting points.
- 5.8.4 Drive the control motor to high fire. If the gas pressure is not within 1/2" w.c. of that indicated on the test tag, adjust the gas pressure regulator to give the required pressure.
- 5.8.5 If the required high fire pressure cannot be achieved by adjusting the regulator, return to low fire, loosen the link and rod connecting points at either Arm C or C1 and move the connecting point in the appropriate direction (see 5.4) without moving Arms C and C1 or changing the low fire flow rate.
- 5.8.6 Tighten the loose connecting points and recheck the gas pressure at high fire.

5.9 OIL FLOW ADJUSTMENT

- 5.9.1 Set the oil pressure regulator for a static output of 60-65 psig. Set the atomizing air filter regulator for a static output pressure of 55 psig.
- 5.9.2 Make sure the burner is in the oil operation mode. Refer back to 4.0, light burner and set control motor at low fire.
- 5.9.3 Read the low fire atomizing air pressure at the nozzle gauge, if it is not the same as on the test tag, adjust it using the screw on top of the atomizing air proportioning regulator. Be sure to tighten the locking nut after the adjustment is made.
- 5.9.4 Low fire oil pressure is adjusted by loosening the rod and link connecting points at Arm D1 and moving Arm D1 until the oil pressure is as indicated on the test tag. This pressure can be read at the loading line gauge on the atomizing air proportioning regulator.
- 5.9.5 Tighten the loose connecting points, drive the control motor to high fire and check the atomizing air pressure at the nozzle gauge. If it is as indicated on the test tag, proceed to 5.9.6, if it is not, adjust the atomizing air filter regulator.
- 5.9.6 If the oil pressure is not as indicated on the test tag, return to low fire, loosen the link and rod connecting points at either D or D1 and move the connecting point in the appropriate direction without moving Arms D and D1 or changing the low fire oil pressure.
- 5.9.7 Tighten the loose connecting points and recheck the oil pressure at high fire.

FIGURE 7
100 & 200 MF

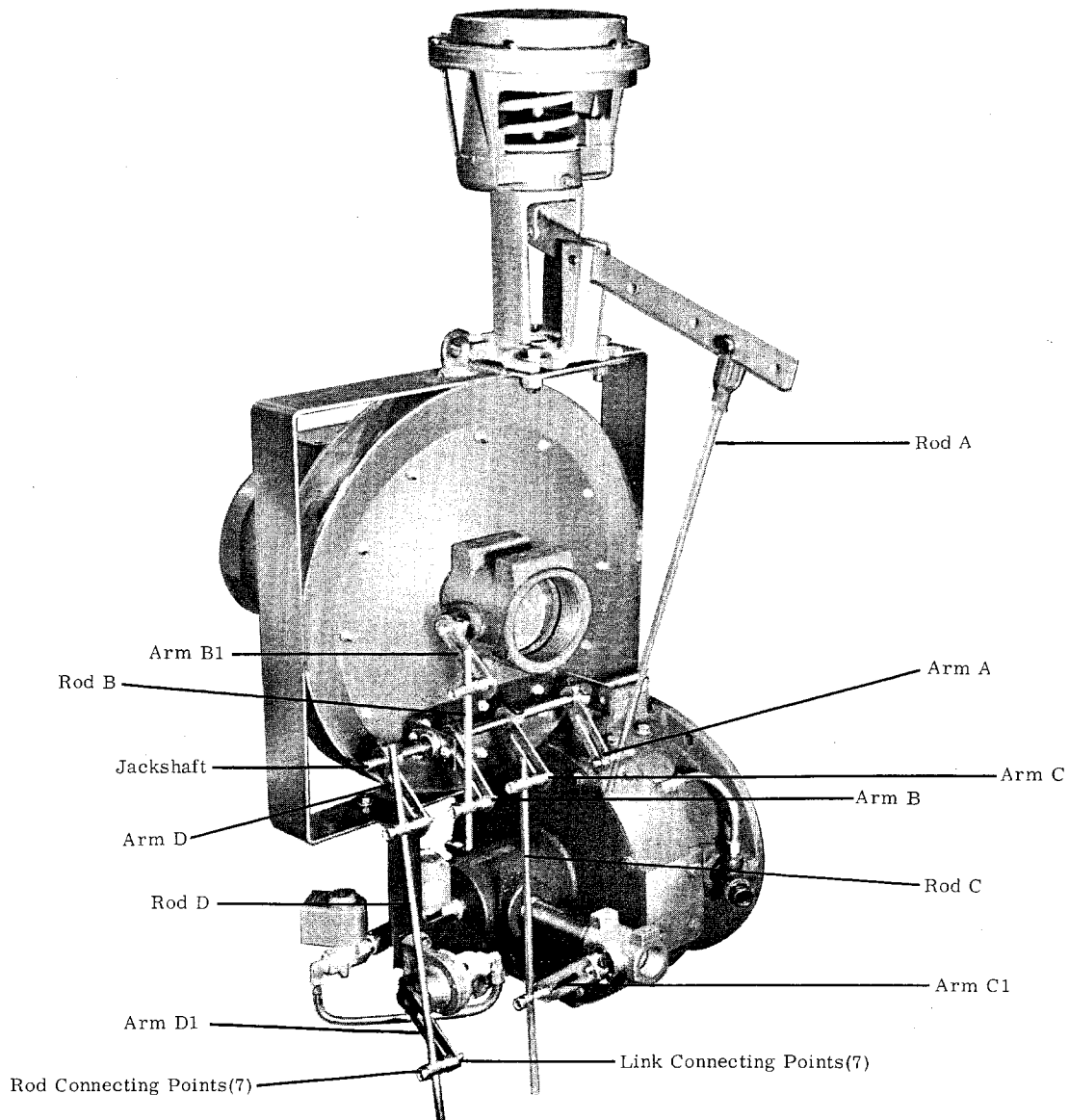

6.0 LINKAGE ADJUSTMENT - 300 & 500 MF (See Figures 5 & 8)

- 6.1 The components involved in the linkage are as follows: Rod A and Driven Arm A transfer the motion of the control motor to the Butterfly Shaft B; Driving Arm C, Rod C and Driven Arm C1 transfer motion from Butterfly Shaft B to the gas butterfly valve; Driving Arm D, Rod D and Driven Arm D1 transfer motion from Butterfly Shaft B to the oil metering valve.
- 6.2 All linkage arms move in an upward direction when going from low to high fire.
- 6.3 When adjusting linkage, start with the driving and driven arms approximately parallel to each other.
- 6.4 Lengthening the distance between the rotating center of the driving arm and the link connecting point on the driving arm will cause the driven arm to move through a larger angle. Shortening this distance will cause the driven arm to move through a smaller angle. Making these adjustments on the driven arm will reverse the results. All linkage adjustments, including those which will alter the high fire rate, must be made with the burner at low fire. Care should be taken not to alter the low fire setting as it serves as a constant reference point. Making an adjustment at the link connecting point ONLY will alter both the high and low firing rates. To maintain one firing rate while changing the other, the link and rod connecting points must both be loosened.

6.6 COMBUSTION AIR FLOW ADJUSTMENT

- 6.6.1 Close the lubricated plug cock and the oil solenoid valves, set the control motor at low fire and start the combustion air blower.
- 6.6.2 Loosen the link and rod connecting points at Arm A and the shaft connecting points for Arms C and D, and set the butterfly valve to give a differential pressure between the burner windbox and the firing chamber of approximately .25" w.c. (low fire).
- 6.6.3 Tighten the loose connecting points.
- 6.6.4 Drive the control motor to high fire. The differential pressure should be 6" w.c. If it is not, return to low fire, loosen the link and rod connecting points at Arm A and move the link connecting point in the appropriate direction (see 5.4) without moving Arm A or changing the low fire flow rate.
- 6.6.5 Tighten the loose connecting points and recheck the high fire differential pressure. Once the burner is firing, it may be necessary to readjust the air flow slightly.

6.7 GAS FLOW ADJUSTMENT

- 6.7.1 Follow steps 5.8.1 through 5.8.6.

6.8 OIL FLOW ADJUSTMENT

- 6.8.1 Follow steps 5.9.1 through 5.9.7.

FIGURE 8
300 & 500 MF

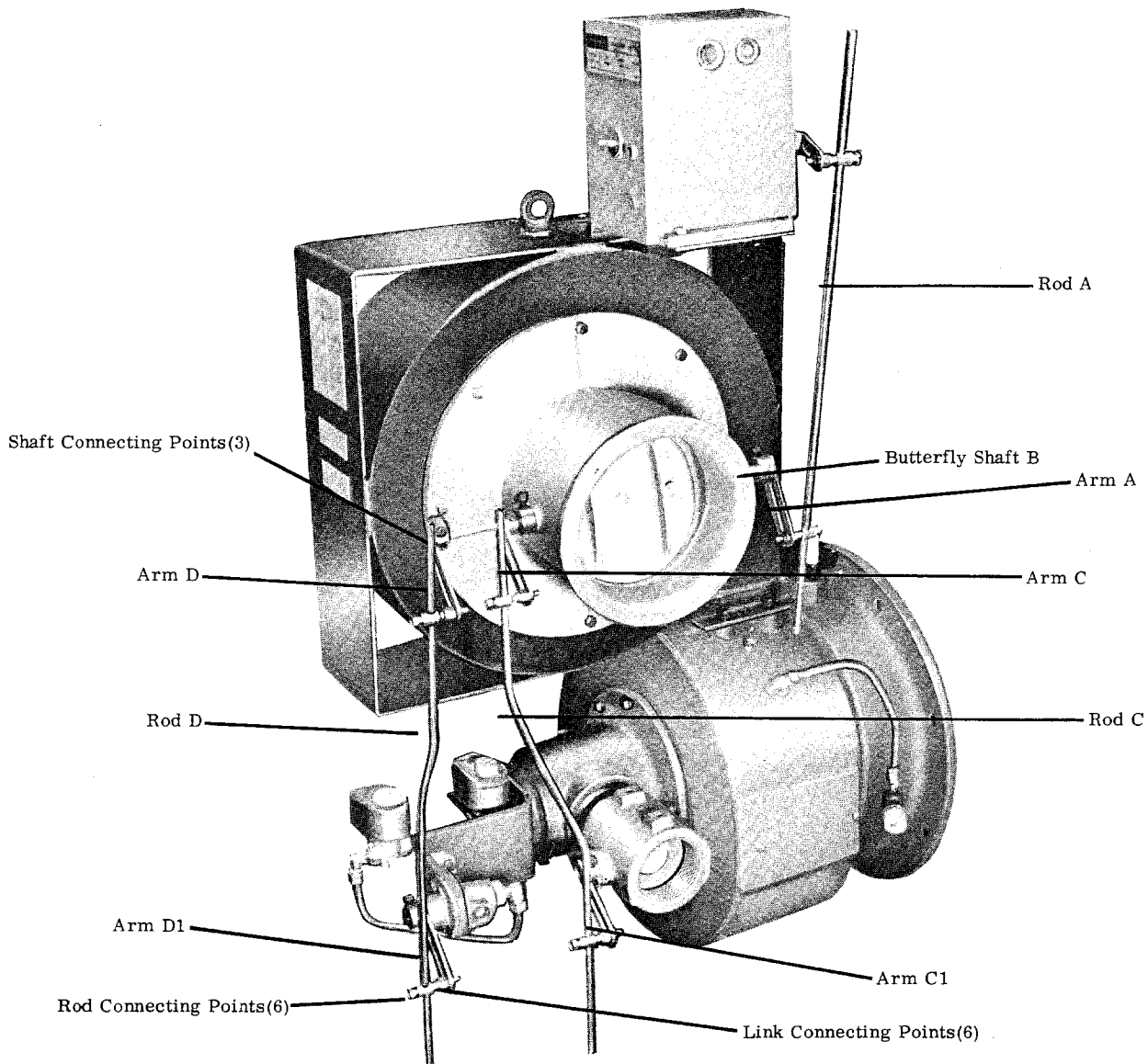

7.0 MAINTENANCE

- 7.1 Air, oil and compressed air filters must be cleaned routinely, depending on ambient conditions.
- 7.2 Fuel oil must be purchased from a dependable source and be free of impurities, and especially, free of sulfur.
- 7.3 Kerosene or hydro-treated oil may be required for the product being processed.
- 7.4 Linkage and valves must be lubricated and inspected to assure proper operation.
- 7.5 Flame monitoring equipment must be cycled, tested, and understood.
- 7.6 Ignition system--spark plugs, transformer and lead wires--must be maintained in topnotch condition.
- 7.7 Oil spills, leaks, etc. must be cleaned up -- just good housekeeping.
- 7.8 Fuel oil piping must be tight, air must be purged from the system, and the oil must be filtered. Dirt will plug nozzles and air bubbles will prevent fuel flow to the nozzle.

7.0 MAINTENANCE (Cont'd)

7.9 Compressed air must be of sufficient quantity, DRY and free of oil and dirt. Air pressure should be steady so it doesn't affect any of the burner controls.

7.9.1 If there is a large amount of water present at a burner, this can be reduced considerably by putting an air/oil separator at each burner with an automatic water drain. The burners already have a filter with a visible bowl to remove the moisture but the amount of water in an air supply may exceed the ability of this filter regulation unit to remove the large quantity of water present. There are several makes of filters available that can be supplied with automatic water drains. This is strictly a stopgap or final filter ahead of the burner, and the least desirable solution.

7.9.2 The preferred method is to remove the moisture from the air to a saturation point below the lowest expected temperature to which the air piping is likely to drop. For most piping in factories or mills, a temperature of 50° F. should be low enough for this purpose. This degree of saturation can only be achieved with refrigeration-type air drying equipment.

Reducing the saturation point of air down to 50° F. reduces the moisture down to 4.076 grains per cu. ft. This compares to 7.980 at 70° F. This is a very significant reduction in water content. Reducing the saturation point below 70° F. is a very good improvement in removing water content from air lines.



ECLIPSE COMBUSTION



Offered By:

Power Equipment Company
2011 Williamsburg Road
Richmond, Virginia 23231
Phone (804) 236-3800
Fax (804) 236-3882

www.peconet.com